

ifm electronic



Operating instructions
Pressure sensor

efector500[®]

PN50XX

UK

701881 / 00 10 / 2004

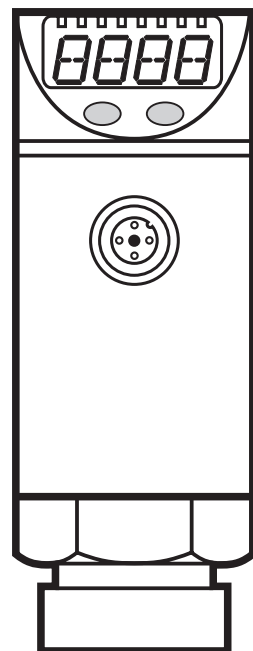

Contents

1 Preliminary note.....	3
1. Symbols used	3
2 Safety instructions	3
3 Functions and features	4
4 Function.....	5
4.1 Processing of the measured signals	5
4.2 Switching function	5
5 Installation	6
6 Electrical connection.....	6
7 Operating and display elements	7
8 Menu.....	8
8.1 Menu structure	8
8.2 Explanation of the menu.....	9
9 Parameter setting	10
9.1 Parameter setting general	10
9.2 Configuring the display (optional).....	12
9.3 Setting the output signal.....	12
9.3.1 Setting the output function	12
9.3.2 Setting the switching limits	12
9.4 User settings (optional)	12
9.4.1 Setting the delay time for OUT1	12
9.4.2 Setting the damping for OUT1.....	12
9.5 Service functions	13
9.5.1 Reading the min./max. values for the system pressure	13
10 Operation.....	13
10.1 Read the set parameter values	13
10.2 Fault indication	13
11 Scale drawing	14
12 Technical data.....	14
12.1 Setting ranges	16
13 Factory setting	17

1 Preliminary note

1. Symbols used

▶ Instruction

> Reaction, result

[...] Designation of buttons, switches or indications

→ Cross-reference



Important note

Non-compliance can result in malfunctions or interference.

UK

2 Safety instructions

- Read this document before installing the unit. Ensure that the product is suitable for your application without any restrictions.
- Non-adherence to the operating instructions or technical data can lead to personal injury and/or damage to property.
- In all applications check compliance of the product materials (→ chapter 12 Technical data) with the media to be measured.
- For gaseous media the application is limited to max. 25 bar.

3 Functions and features

The unit monitors the system pressure of machines and installations.

Applications

Type of pressure: relative pressure

Order no.	Measuring range		Permissible overload pressure		Bursting pressure	
	bar	PSI	bar	PSI	bar	PSI
PN5000	0...400	0...5 800	600	8 700	1 000	14 500
PN5001	0...250	0...3 625	400	5 800	850	12 300
PN5002	0...100	0...1 450	300	4 350	650	9 400
PN5003	0...25	0...363	150	2 175	350	5 075
PN5004	-1...10	-14.5...145	75	1 087	150	2 175
PN5006	0...2.5	0...36.3	20	290	50	725
PN5007	0...1	0...14.5	10	145	30	450

$$\text{MPa} = \text{bar} \div 10 / \text{kPa} = \text{bar} \times 100$$



Static and dynamic overpressures exceeding the indicated overload pressure are to be avoided by taking appropriate measures.

The indicated bursting pressure must not be exceeded. Even if the bursting pressure is exceeded only for a short time, the unit can be destroyed.

NOTE: Risk of injury!

For gaseous media the application is limited to max. 25 bar.

High-pressure units (400 bar) are supplied with an integrated damping device to comply with the regulations for UL approval and to avoid any risk of injury in case of bursting when bursting pressure is exceeded.

- When the damping device is removed the damping device can become unusable.
- When the damping device is removed the unit can no longer be used under UL conditions,

If you have any questions, please contact ifm electronic's sales specialists.

4 Function

4.1 Processing of the measured signals

- The unit shows the current system pressure on its display.
- It generates 1 output signal according to the parameter setting.

OUT1	switching signal for pressure limit values
-------------	--

4.2 Switching function

OUT1 changes its switching state if it is above or below the set switching limits (SP1, rP1). The following switching functions can be selected:

- Hysteresis function / normally open: [OU1] = [Hno] (→ fig. 1).
- Hysteresis function / normally closed: [OU1] = [Hnc] (→ fig. 1).

First the set point (SP1) is set, then the reset point (rP1) at the requested distance.

- Window function / normally open: [OU1] = [Fno] (→ fig. 2).
- Window function / normally closed: [OU1] = [Fnc] (→ fig. 2).

The width of the window can be set by means of the distance between SP1 and rP1. SP1 = maximum value, rP1 = minimum value.

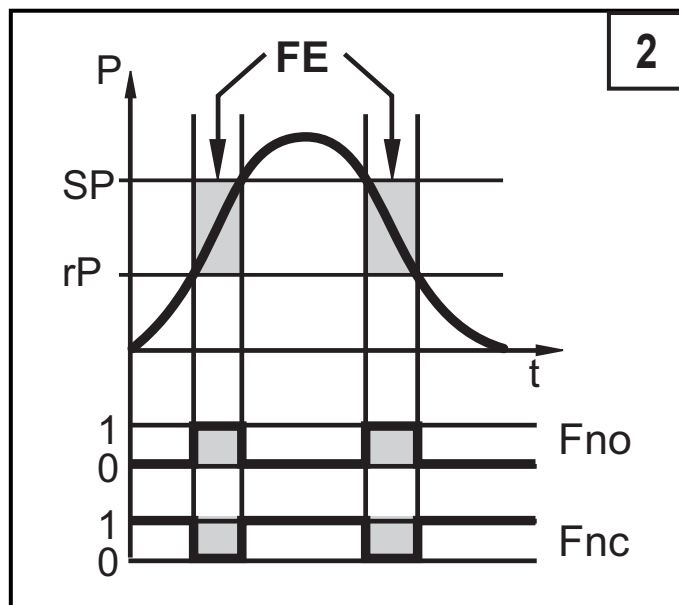
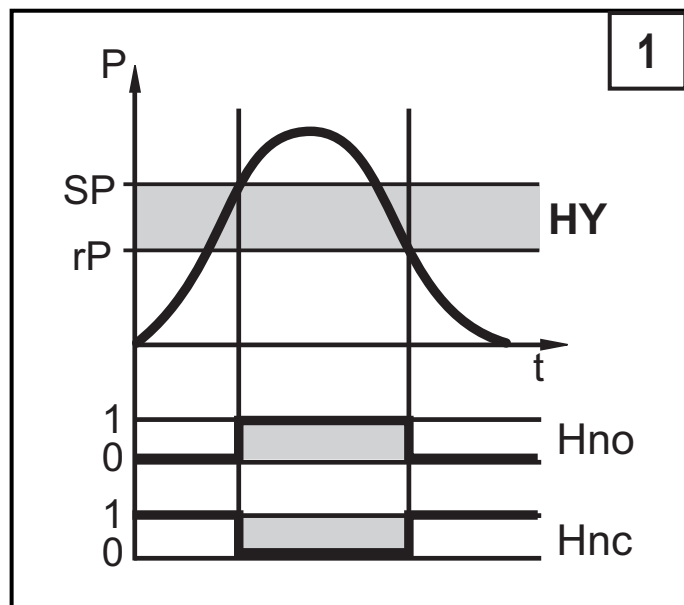

P = system pressure; HY = hysteresis; FE = window

5 Installation



Before mounting and removing the sensor, make sure that no pressure is applied to the system.

- ▶ Insert the unit in a G $\frac{1}{4}$ process connection.
- ▶ Tighten firmly.

6 Electrical connection



The unit must be connected by a qualified electrician.

The national and international regulations for the installation of electrical equipment must be adhered to.

Voltage supply to EN50178, SELV, PELV.

For the scope of validity cULus:

The unit shall be supplied from an isolating source and protected by an overcurrent device. The „limited voltage“ requirements according to UL508 must be complied with.

- ▶ Disconnect power.
- ▶ Connect the unit as follows:

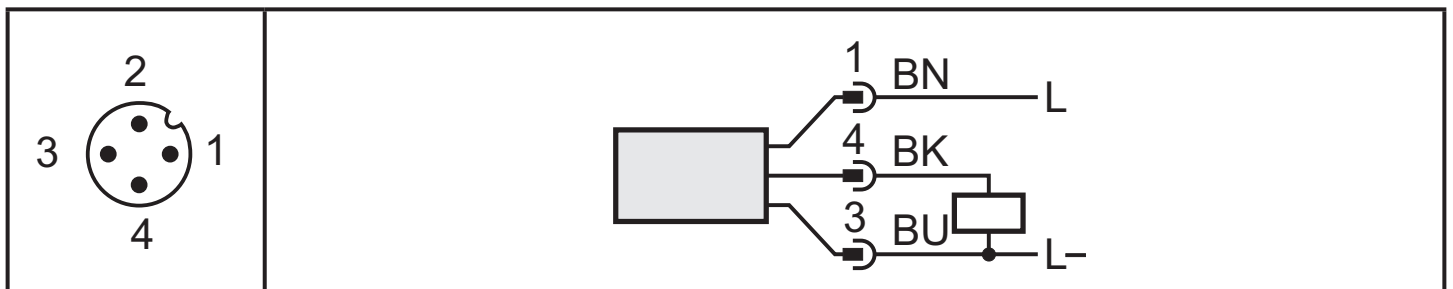

Pin 1	Ub+
Pin 3	Ub-
Pin 4	switching output for pressure monitoring
Pin 2	not connected

Core colours of ifm sockets:

1 = BN (brown), 3 = BU (blue), 4 = BK (black).

7 Operating and display elements

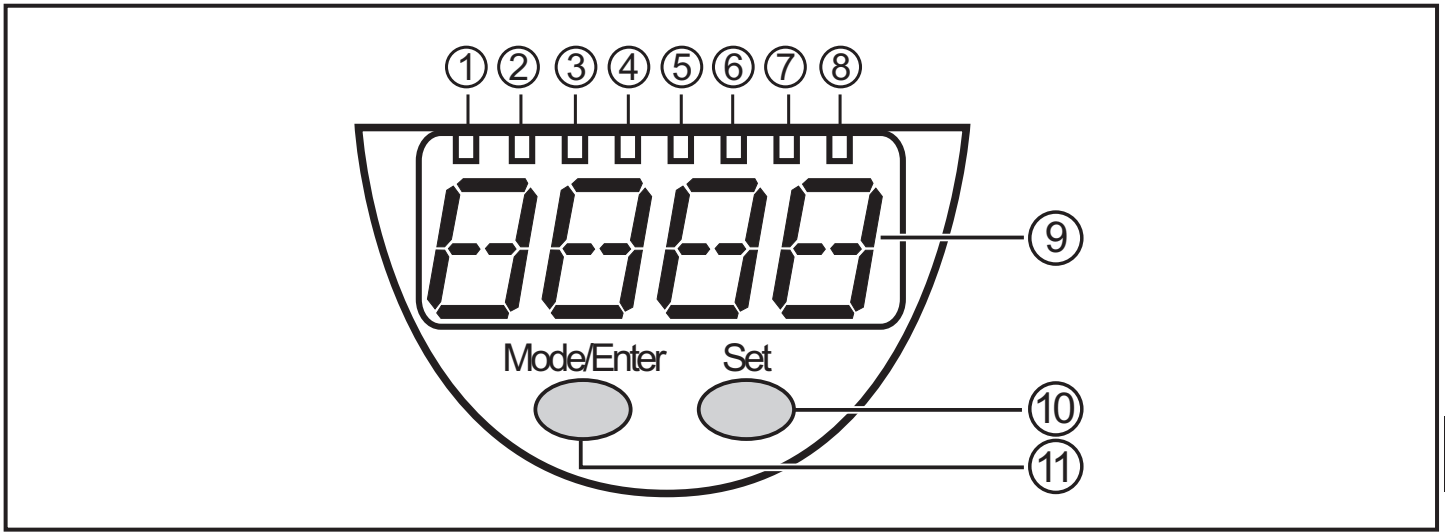

UK

1 to 8: Indicator LEDs

- LED 1 to LED 4 = system pressure in unit of measurement as indicated on the label.
- LED 4 not used for units with 3 adjustable units of measurement.
- LEDs 5 to 7 not used.
- LED 8 = switching state of the output.

9: Alphanumeric display, 4 digits

- Indication of the current system pressure.
- Indication of the parameters and parameter values.

10: Set pushbutton

- Setting of the parameter values (scrolling by holding pressed, incremental by pressing briefly).

11: Mode/Enter pushbutton

- Selection of the parameters and acknowledgement of the parameter values.

8 Menu

8.1 Menu structure

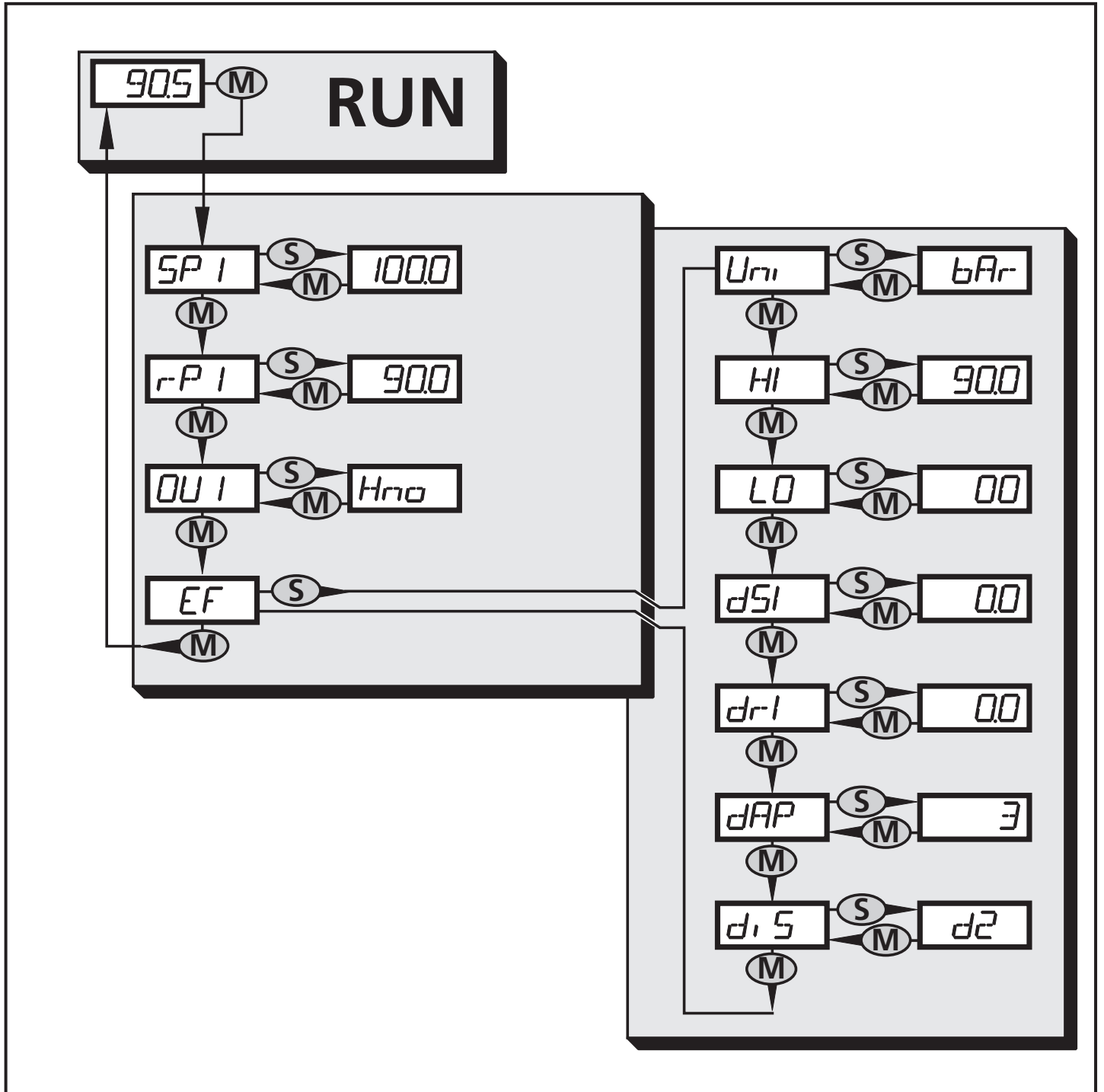

8.2 Explanation of the menu

SP1/rP1	Maximum / minimum value for system pressure, at which output 1 changes its switching status.
OU1	Output function for OUT1: <ul style="list-style-type: none"> Switching signal for the limit values: hysteresis function [H ..] or window function [F ..], normally open [. no] or normally closed [. nc] each.
EF	Extended functions / Opening menu level 2.
Uni	Standard unit of measurement for the system pressure.
HI	Maximum value memory for the system pressure.
LO	Minimum value memory for the system pressure (only PN5004).
dS1	Switch-on delay for für OUT1.
dr1	Reset delay für OUT1.
dAP	Damping for OUT1.
diS	Update rate and orientation of the display.



UK

9 Parameter setting

During the parameter setting process the unit remains in the operating mode. It continues its monitoring function with the existing parameters until parameter setting has been terminated.

9.1 Parameter setting general

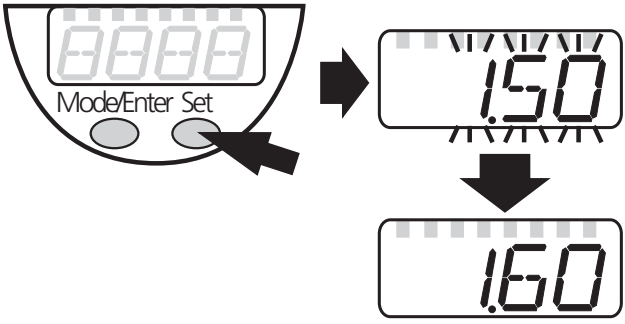
Each parameter setting requires 3 steps:

<p>1</p>	<p>Selecting parameter</p> <ul style="list-style-type: none"> ▶ Press [Mode/Enter] until the requested parameter is displayed. 	
<p>2</p>	<p>Setting the parameter value</p> <ul style="list-style-type: none"> ▶ Press [Set] and keep the button pressed. > Current setting value of the parameter bit flashes for 5 s. > After 5 s: Setting value is changed: incremental by pressing briefly or scrolling by holding pressed. 	
<p>The numerical values are incremented continuously. If the value is to be reduced: Let the display move to the maximum setting value. Then the cycle starts again at the minimum setting value.</p>		
<p>3</p>	<p>Acknowledge parameter value</p> <ul style="list-style-type: none"> ▶ Press [Mode/Enter] briefly. > The parameter is displayed again. The new setting value is stored. 	
<p>Set more parameters:</p> <ul style="list-style-type: none"> ▶ Start again with step 1. 		
<p>Finishing parameter setting:</p> <ul style="list-style-type: none"> ▶ Press [Mode/Enter] several times until the current measured value is displayed or wait for 15 s. > The unit returns to the operating mode. 		

- Changing from menu level 1 to menu level 2:

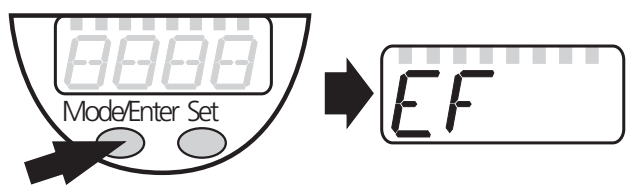
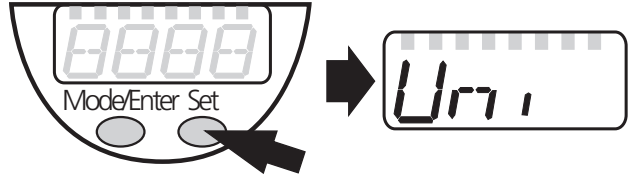
<ul style="list-style-type: none"> ▶ [Press [Mode/Enter] until [EF] is displayed. <p>If the submenu is protected with an access code, [Cod1] flashes in the display.</p> <ul style="list-style-type: none"> ▶ Press [Set] and hold it pressed until the valid code no. is shown. ▶ Then briefly press [Mode/Enter]. <p>Delivery by ifm electronic: no access restriction.</p>	
<ul style="list-style-type: none"> ▶ Press [Set] briefly. > The first parameter of the submenu is displayed (here: [Uni]). 	

UK

- Locking / unlocking

The unit can be locked electronically to prevent unintentional wrong settings.

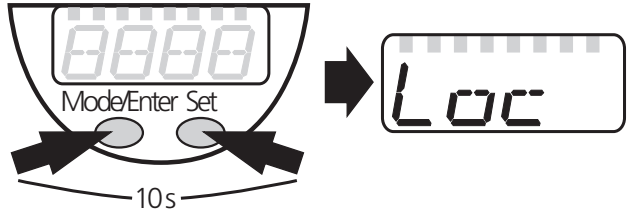
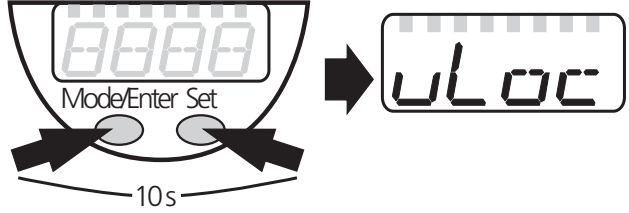
<ul style="list-style-type: none"> ▶ Ensure that the unit is in the normal operating mode. ▶ Press [Mode/Enter] + [Set] for 10 s. > [Loc] is displayed. 	
<p>During operation [Loc] is displayed briefly when you try to change parameter values.</p>	
<p>For unlocking:</p> <ul style="list-style-type: none"> ▶ Press [Mode/Enter] + [Set] for 10 s. > [uLoc] is displayed. 	

On delivery: Unlocked.

- Timeout:

If no button is pressed for 15 s while the parameters are being set, the unit returns to the operating mode with unchanged values.

9.2 Configuring the display (optional)

<ul style="list-style-type: none"> ▶ Select [Uni] and set the unit of measurement: [bar], [mbar], [MPa], [kPa], [PSI], for PN5007 in addition [inHg]. 	<i>Uni</i>
<ul style="list-style-type: none"> ▶ Select [diS] and set update rate and orientation of the display: <ul style="list-style-type: none"> - [d1]: Update of the measured value every 50 ms. - [d2]: Update of the measured value every 200 ms. - [d3]: Update of the measured value every 600 ms. - [rd1], [rd2], [rd3]: Display like d1, d2, d3; rotated by 180°. - [OFF]: The display is deactivated in the operating mode. 	<i>d1 S</i>

9.3 Setting the output signal

9.3.1 Setting the output function

<ul style="list-style-type: none"> ▶ Select [OU1] and set the switching function: <ul style="list-style-type: none"> - [Hno] = hysteresis function / normally open, - [Hnc] = hysteresis function / normally closed, - [Fno] = window function / normally open, - [Fnc] = window function / normally closed. 	<i>OU 1</i>
--	-------------

9.3.2 Setting the switching limits

<ul style="list-style-type: none"> ▶ Select [SP1] and set the value at which the output switches. 	<i>SP 1</i>
<ul style="list-style-type: none"> ▶ Select [rP1] and set the value at which the output switches back. rP1 is always lower than SP1. The unit only accepts values which are lower than SP1. 	<i>rP 1</i>

9.4 User settings (optional)

9.4.1 Setting the delay time for OUT1

<p>[dS1] = switch-on delay, [dr1] = switch-off delay.</p> <ul style="list-style-type: none"> ▶ Select [dS1] or [dr1] set value between 0.1 und 50 s (at 0.0 the delay time is not active). 	<i>dS 1</i> <i>dr 1</i>
---	----------------------------

9.4.2 Setting the damping for OUT1

<ul style="list-style-type: none"> ▶ Select [dAP], set value. dAP-value = response time between pressure change and change of the switching status in milliseconds (ms). The following values can be set. They define the switching frequency (f) of the output: <table border="1" style="width: 100%; border-collapse: collapse; text-align: center;"> <tr> <td>dAP</td> <td>3</td> <td>6</td> <td>10</td> <td>17</td> <td>30</td> <td>60</td> <td>125</td> <td>250</td> <td>500</td> </tr> <tr> <td>f [Hz]</td> <td>170</td> <td>80</td> <td>50</td> <td>30</td> <td>16</td> <td>8</td> <td>4</td> <td>2</td> <td>1</td> </tr> </table>	dAP	3	6	10	17	30	60	125	250	500	f [Hz]	170	80	50	30	16	8	4	2	1	<i>dAP</i>
dAP	3	6	10	17	30	60	125	250	500												
f [Hz]	170	80	50	30	16	8	4	2	1												

9.5 Service functions

9.5.1 Reading the min./max. values for the system pressure

<ul style="list-style-type: none">▶ Select [HI] or [LO], press [Set] briefly. [HI] = maximum value, [LO] = minimum value. Delete memory: <ul style="list-style-type: none">▶ Select [HI] or [LO].▶ Press [Set] until [----] is displayed.▶ Press [Mode/Enter] briefly. [LO] is available only for PN5004.	 <p>The image shows a digital display with two lines. The top line displays 'HI' and the bottom line displays 'LO'.</p>
---	--

UK

10 Operation

After power on of the supply voltage the unit is in the Run mode (= normal operation). It carries out its measurement and evaluation functions and generates output signals according to the set parameters.

Operation indication → chapter 7 Operating and display elements.

10.1 Read the set parameter values

- ▶ Press [Mode/Enter] briefly until the requested parameter is displayed.
- ▶ Press [Set] briefly.
- > The unit indicates the corresponding parameter value for 15 s. After another 15 s the unit returns to the Run mode.

10.2 Fault indication

[OL]	overload pressure (measuring range exceeded)
[UL]	underpressure range (measuring range below the minimum value)
[SC1]	short circuit in OUT1; the output is switched off as long as the short circuit exists
[Err]	(flashing) internal fault
The faults SC1 and Err are indicated even if the display is deactivated.	

11 Scale drawing

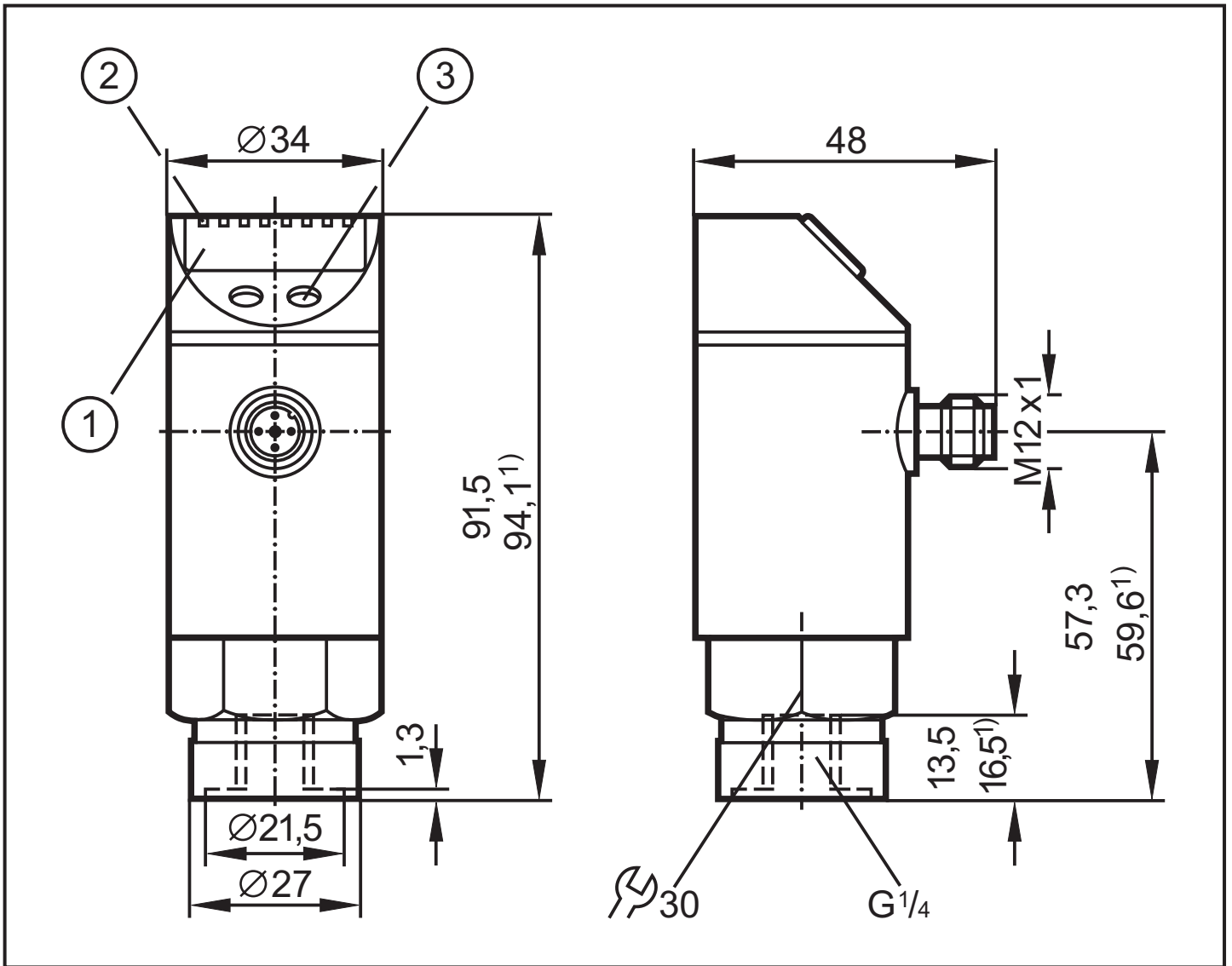

Dimensions are in millimeters

¹⁾ = dimensions for PN5000

1: display

2: LED's

3: programming button

12 Technical data

Operating voltage [V].....	18...36 DC ¹⁾
Current rating [mA].....	250
Current consumption [mA].....	< 50
Reverse polarity and overload protected.....	up to 40 V
Short-circuit protected; Watchdog	
Voltage drop [V]	< 2
Power-on delay time [s]	0.3
Switching frequency [Hz]	max.170

Accuracy / deviations (in % of the span)

- Accuracy of switch point	< ± 0.5
- Characteristics deviation	< ± 0.25 (BFSL) / < ± 0.5 (LS)
- Hysteresis.....	< 0.25
- Repeatability (with temperature fluctuations < 10K).....	< ± 0.1
- Long-time stability (in% of the span per year).....	< ± 0.05
- Temperature coefficients (TEMPCO) in the compensated temperature range 0 ... +80°C (in% of the span per 10 K)	
- greatest TEMPCO of the zero point / of the span	< ± 0.2 / < ± 0.2

Materials (wetted parts)	stainless steel (303S22); ceramics; FPM (Viton)
Housing material	stainless steel (304S15); stainless steel (316S12); PBTP (Pocan); PEI; FPM (Viton); EPDM/X (Santoprene) ²⁾
Protection	IP 67 III ³⁾
Protection	IP 65 III ⁴⁾
Insulation resistance [MΩ]	> 100 (500 V DC)
Shock resistance [g]	50 (DIN / IEC 68-2-27, 11ms)
Vibration resistance [g]	20 (DIN / IEC 68-2-6, 10 - 2000 Hz)
Switching cycles min.	100 million
Operating temperature [°C]	-20...80 (UB < 32 V) / -20...60 (UB > 32 V)
Medium temperature [°C]	-25 ... +80
Storage temperature[°C].....	-40 ... +100
EMC EN 61000-4-2 ESD:	4 / 8 KV
EN 61000-4-3 HF radiated:	10 V/m
EN 61000-4-4 Burst:	2 KV
EN 61000-4-5 Surge:	0.5 / 1 KV
EN 61000-4-6 HF conducted:	10 V

UK

1) to EN50178, SELV, PELV

2) in addition PTFE for PN5003...PN5007

3) for PN5000...PN5002

4) for PN5003...PN5007

BFSL = Best Fit Straight Line / LS = Limit Value Setting

12.1 Setting ranges

		SP1 / SP2		rP1 / rP2		ΔP
		min	max	min	max	
PN5000	bar	4	400	2	398	2
	PSI	60	5790	30	5760	30
	MPa	0.4	40.0	0.2	39.8	0.2
PN5001	bar	2	250	1	249	1
	PSI	40	3620	20	3600	20
	MPa	0.2	25.0	0.1	24.9	0.1
PN5002	bar	1.0	100.0	0.5	99.5	0.5
	PSI	20	1450	10	1440	10
	MPa	0.10	10.00	0.05	9.95	0.05
PN5003	bar	0.2	25.0	0.1	24.9	0.1
	PSI	4	362	2	360	2
	MPa	0.02	2.50	0.01	2.49	0.01
PN5004	bar	-0.90	10.00	-0.95	9.95	0.05
	PSI	-12	145	-13	144	1
	MPa	-0.090	1.000	-0.095	0.995	0.005
PN5006	bar	0.02	2.50	0.01	2.49	0.01
	PSI	0.4	36.2	0.2	36.0	0.2
	kPa	2	250	1	249	1
PN5007	mbar	10	1000	5	995	5
	PSI	0.2	14.5	0.1	14.4	0.1
	kPa	1.0	100.0	0.5	99.5	0.5
	inHg	0.3	29.5	0.2	29.4	0.1

ΔP = increments

13 Factory setting

	Factory setting	User setting
SP1	25% VMR*	
rP1	23% VMR*	
OU1	Hno	
dS1	0,0	
dr1	0,0	
dAP	6	
diS	d2	
Uni	bAr / mbAr	

* = the indicated percentage of the final value of the measuring range (VMR) of the corresponding sensor in bar / mbar is set.

Technical data and further information at
www.ifm-electronic.com → Select your country → Data sheet direct:

UK